

## European Style Interchangeable Head Torque Wrench Series

# SCL-MH / SCSP-MH

Newly upgraded models with slim design and distinctive coating

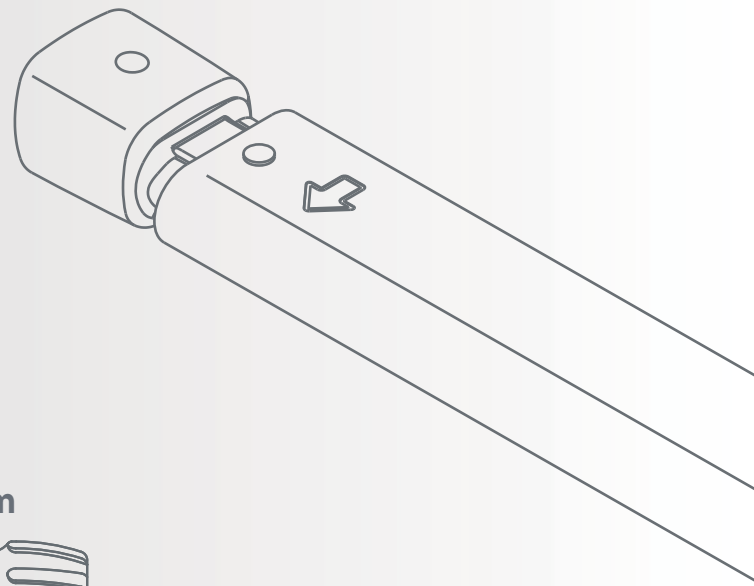
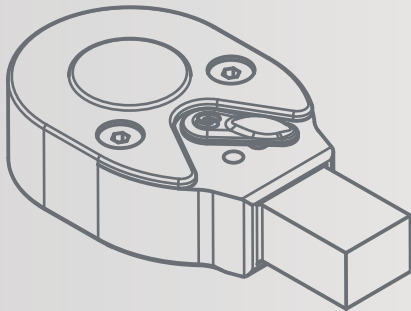

## SCL-MH

Adjustable Type  
Range 0.4 - 200 N·m

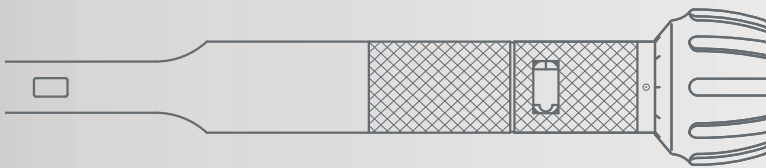

## SCSP-MH

Preset Type  
Range 0.3 - 200 N·m

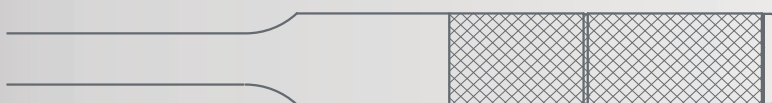

Your Torque Partner





## SCL-MH

Accuracy ± 3 %

### Specifications

MODEL	TORQUE RANGE [N·m]	1 GRAD.	OVERALL LENGTH [mm]	WEIGHT [kg]
SCL2N-9X12-MH	0.4 - 2	0.02	153	0.15
SCL5N-9X12-MH	1 - 5	0.05	153	0.15
SCL10N-9X12-MH	2 - 10	0.1	187	0.18
SCL15N-9X12-MH	3 - 15	0.1	187	0.18
SCL25N-9X12-MH	5 - 25	0.25	215	0.22
SCL50N-9X12-MH	10 - 50	0.5	239	0.4
SCL100N-9X12-MH	20 - 100	1	313	0.58
SCL200N-14X18-MH	40 - 200	2	464	1.28

**Torque setting:** Easy adjust by external scale and knob



## SCSP-MH

Accuracy ± 3 %

### Specifications

MODEL	TORQUE RANGE [N·m]	OVERALL LENGTH [mm]	WEIGHT [kg]
SCSP1.5N-9X12-MH	0.3 - 1.5	144	0.12
SCSP3N-9X12-MH	0.6 - 3	144	0.12
SCSP6N-9X12-MH	1 - 6	178	0.15
SCSP12N-9X12-MH	2 - 12	178	0.15
SCSP25N-9X12-MH	5 - 25	204	0.19
SCSP50N-9X12-MH	10 - 50	222	0.33
SCSP100N-9X12-MH	20 - 100	294	0.49
SCSP200N-14X18-MH	40 - 200	439	1.11

**Torque setting:** Use a special adjusting tool (sold separately) with a torque wrench tester.

Adjusting tool: No. 931 for SCSP1.5N-9X12-MH to SCSP25N-9x12-MH

No. 930 for SCSP50N-9X12-MH to SCSP200N-9x12-MH



- The appearance and specifications are subject to change for improvement without prior notice.
- All right reserved. No reproduction or republication without written permission.
- ©Tohnichi Mfg. Co., Ltd. All Rights Reserved.

### TOHNICHI MFG CO., LTD.

URL <http://www.global-tohnichi.com>

E-mail [overseas@tohnichi.co.jp](mailto:overseas@tohnichi.co.jp)

### N.V. TOHNICHI EUROPE S.A.

E-mail [europa@tohnichi.com](mailto:europa@tohnichi.com)

### TOHNICHI AMERICA CORP.

URL <http://www.tohnichi.com>

E-mail [inquiry@tohnichi.com](mailto:inquiry@tohnichi.com)

### TOHNICHI SHANGHAI MFG. CO., LTD.

URL <http://www.tohnichi-sh.com>

E-mail [sales@tohnichi-sh.com](mailto:sales@tohnichi-sh.com)



Your Torque Partner

**TOHNICHI**