

ENG

BANKO

INDUSTRIAL POWER TOOLS

MADE IN EU / CROATIA



Turbine grinders - Vane grinders - Robot spindles - Air motors

PATENTED TECHNOLOGY

THE SMALL BEAST

BANKO
INDUSTRIAL POWER TOOLS

The most powerful small hand-held grinder available in the market



Unmatched power-to-weight ratio provide extreme material removal rate with minimum effort which allows new levels of productivity

Benefits

- ▶ The most efficient grinding with half the weight for an extreme material removal rate with minimum effort
- ▶ Much less insensitivity to variation of pressure, impossible to stall with the right hose and pressure
- ▶ Grinding with much less vibration due to grinding of the wheel at the constant right speed
- ▶ Oil-less grinding which enables clean surface and more environmentally friendly operation
- ▶ Ergonomically shaped and balanced design for less operator fatigue and easy control

Features

- ▶ The most efficient 6 stage turbine motor
- ▶ Precise stainless steel governor working under any pressure and condition
- ▶ Adjustable wheel guard

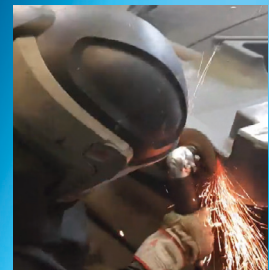

TURBINE ANGLE GRINDER
ABSOLUTELY OIL-FREE



TURBINE T-21

Order number	GTB21 D12 DW	GTB21 D85 DW	GTB21 D12 DW58	GTB21 D85 DW58
Model	Banko T2 Angle	Banko T2 Angle	Banko T2 Angle	Banko T2 Angle
Max. free speed (rpm)	12000	8500	12000	8500
Spindle thread	M14	M14	5/8"-11	5/8"-11
Rec. max. dia. grinding wheel	125	180	125	180
Maximum Power (kW)	3.5	3.5	3.5	3.5
Weight (kg)	2.2	2.5	2.2	2.5
Length (mm)	243	243	243	243
Rec. hose dia. (mm)	13	13	13	13
Air inlet thread	1/2"	1/2"	1/2"	1/2"
Optimal pressure (bar)	6.3	6.3	6.3	6.3
Air consumption max/free (l/sec)	45/14	45/14	45/14	45/14
Exhaust	Lateral	Lateral	Lateral	Lateral
Noise (dB)	78	79	78	79
Vibration	<3 m/s ²	<3 m/s ²	<3 m/s ²	<3 m/s ²

We recommend gear grease (article 490-16-103) for relubrication.



TURBINE T-21 LONG

Order number	GTB21 DE12 DW	GTB21 DE85 DW	GTB21 DE12 DW58	GTB21 DE85 DW58
Model	Banko T21 Angle long	Banko T21 Angle long	Banko T21 Angle long	Banko T21 Angle long
Max. free speed (rpm)	12000	8500	12000	8500
Spindle thread	M14	M14	5/8"-11	5/8"-11
Rec. max. dia. grinding wheel	125	180	125	180
Maximum Power (kW)	3.5	3.5	3.5	3.5
Weight (kg)	3.65	3.85	3.65	3.85
Length (mm)	543	543	543	543
Rec. hose dia. (mm)	13	13	13	13
Air inlet thread	1/2"	1/2"	1/2"	1/2"
Optimal pressure (bar)	6.3	6.3	6.3	6.3
Air consumption max/free (l/sec)	45/14	45/14	45/14	45/14
Exhaust	Lateral	Lateral	Lateral	Lateral
Noise (dB)	78	79	78	79
Vibration	<3 m/s ²	<3 m/s ²	<3 m/s ²	<3 m/s ²

THE BEAST

BANKO
INDUSTRIAL POWER TOOLS

The most powerful hand-held grinder available in the market



Unmatched power-to-weight ratio provide extreme material removal rate with minimum effort which allows new levels of productivity

Benefits

- ▶ The most efficient grinding with half the weight for an extreme material removal rate with minimum effort
- ▶ Much less insensitivity to variation of pressure, impossible to stall with the right hose and pressure
- ▶ Grinding with much less vibration due to grinding of the wheel at the constant right speed
- ▶ Oil-less grinding which enables clean surface and more environmentally friendly operation
- ▶ Ergonomically shaped and balanced design for less operator fatigue and easy control

Features

- ▶ The most efficient 6 stage turbine motor
- ▶ Precise stainless steel governor working under any pressure and condition
- ▶ Adjustable wheel guard



TURBINE ANGLE GRINDER
ABSOLUTELY OIL-FREE

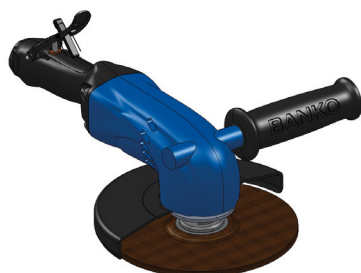

TURBINE T-32

Order number	GTB32 A85 DW	GTB32 A66 DW	GTB32 A85 DW58	GTB32 A66 DW58
Model	Banko T32 Angle	Banko T32 Angle	Banko T32 Angle	Banko T32 Angle
Max. free speed (rpm)	8500	6600	8500	6600
Spindle thread	M14	M14	5/8"-11	5/8"-11
Rec. max. dia. grinding wheel	180	230	180	230
Maximum Power (kW)	5.0	5.0	5.0	5.0
Weight (kg)	3.3	3.5	3.3	3.5
Lenght (mm)	313	313	313	313
Rec. hose dia. (mm)	16	16	16	16
Air inlet thread	1/2"	1/2"	1/2"	1/2"
Optimal pressure (bar)	6.3	6.3	6.3	6.3
Air consumption max/free (l/sec)	52/18	52/19	52/18	52/19
Exhaust	Lateral	Lateral	Lateral	Lateral
Noise (dB)	87	87	87	87
Vibration	3.5 m/s ²	3.5 m/s ²	3.5 m/s ²	3.5 m/s ²

TURBINE T-32

Order number	GTB32 A60 CW	GTB32 A60 CW58
Model	Banko T32 Angle	Banko T32 Angle
Max. free speed (rpm)	6000	6000
Spindle thread	M14	5/8"-11
Rec. max. dia. grinding wheel	150	150
Maximum Power (kW)	5.0	5.0
Weight (kg)	3.5	3.5
Lenght (mm)	313	313
Rec. hose dia. (mm)	16	16
Air inlet thread	1/2"	1/2"
Optimal pressure (bar)	6.3	6.3
Air consumption max/free (l/sec)	52/19	52/19
Exhaust	Lateral	Lateral
Noise (dB)	87	87
Vibration	3.5 m/s ²	3.5 m/s ²



We recommend the gear grease (article 490-16-103) for relubrication.



TURBINE T-32 LONG

Order number	GTB32 A85 LDW	GTB32 A66 LDW	GTB32 A85 LDW58	GTB32 A66 LDW58
Model	Banko T32 Angle long	Banko T32 Angle long	Banko T32 Angle long	Banko T32 Angle long
Max. free speed (rpm)	8500	6600	8500	6600
Spindle thread	M14	M14	5/8"-11	5/8"-11
Rec. max. dia. grinding wheel	180	230	180	230
Maximum Power (kW)	5.0	5.0	5.0	5.0
Weight (kg)	4.2	4.5	4.2	4.5
Length (mm)	463	463	463	463
Rec. hose dia. (mm)	16	16	16	16
Air inlet thread	1/2"	1/2"	1/2"	1/2"
Optimal pressure (bar)	6.3	6.3	6.3	6.3
Air consumption max/free (l/sec)	52/19	52/19	52/19	52/19
Exhaust	Lateral	Lateral	Lateral	Lateral
Noise (dB)	87	87	87	87
Vibration	3.5 m/s ²	3.5 m/s ²	3.5 m/s ²	3.5 m/s ²

We recommend the gear grease (article 490-16-103) for relubrication.

Available on request: Disc washer and nut for cutting



PO-05 ROTATING ADAPTER SIDE HANDLE

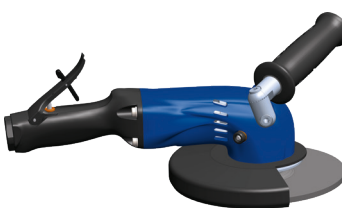
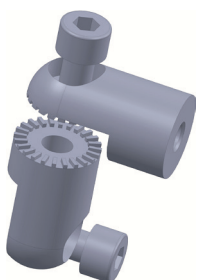

TURBINE ANGLE GRINDER
ABSOLUTELY OIL-FREE



TURBINE SANDER

Order number	GTB21 D12 S	GTB21 D85 S	GTB21 D12 S58	GTB21 D85 S58
Model	Banko T21 Angle Sander	Banko T21 Angle Sander	Banko T21 Angle Sander	Banko T21 Angle Sander
Max. free speed (rpm)	12000	8500	12000	8500
Spindle thread	M14	M14	5/8"-11	5/8"-11
Rec. max. dia. grinding wheel	125	180	125	180
Maximum Power (kW)	3.5	3.5	3.5	3.5
Weight (kg)	1.9	1.9	1.9	1.9
Lenght (mm)	243	243	243	243
Rec. hose dia. (mm)	13	13	13	13
Air inlet thread	1/2"	1/2"	1/2"	1/2"
Optimal pressure (bar)	6.3	6.3	6.3	6.3
Air consumption max/free (l/sec)	45/14	45/14	45/14	45/14
Exhaust	Lateral	Lateral	Lateral	Lateral
Noise (dB)	78	79	78	79
Vibration	<3 m/s ²	<3 m/s ²	<3 m/s ²	<3 m/s ²



TURBINE SANDER

Order number	GTB32 A85 S	GTB32 A85 S58
Model	Banko T32 Angle Sander	Banko T32 Angle Sander
Max. free speed (rpm)	8500	8500
Spindle thread	M14	5/8"-11
Rec. max. dia. grinding wheel	180	180
Maximum Power (kW)	5.0	5.0
Weight (kg)	3.3	3.3
Lenght (mm)	313	313
Rec. hose dia. (mm)	16	16
Air inlet thread	1/2"	1/2"
Optimal pressure (bar)	6.3	6.3
Air consumption max/free (l/sec)	52/19	52/19
Exhaust	Lateral	Lateral
Noise (dB)	87	87
Vibration	3.5 m/s ²	3.5 m/s ²

TURBINE T21 BURNISHER

Order number	GTB21 D30 BS
Model	Banko T21 Angle Burnisher
Max. free speed (rpm)	3000
Spindle thread	19x100xM14
Rec. max. dia. grinding wheel	100
Maximum Power (kW)	3.5
Weight (kg)	2.5
Lenght (mm)	243
Rec. hose dia. (mm)	13
Air inlet thread	1/2"
Optimal pressure (bar)	6.3
Air consumption max/free (l/sec)	45/14
Exhaust	Lateral
Noise (dB)	79
Vibration	<3 m/s ²

DIE ANGLE M-2

Die angle grinder (DW)

Order number	GAB21 D12 DW	GAB21 D85 DW
Model	Banko M2 DIE Angle	Banko M2 DIE Angle
Max. free speed (rpm)	12000	8500
Spindle thread	M14	M14
Rec. max. dia. grinding wheel	125	180
Maximum Power (kW)	2.2	2.2
Weight (kg)	1.9	1.9
Length (mm)	265	265
Rec. hose dia. (mm)	13	13
Air inlet thread	1/2"	1/2"
Optimal pressure (bar)	6.3	6.3
Air consumption max/free (l/sec)	32/16	32/16
Exhaust	Rear	Rear
Noise (dB)	90	90
Vibration	<3.2 m/s ²	<3.2 m/s ²



ANGLE M-3

Angle grinder (DW)



ANGLE M-4

Angle grinder (DW)

Order number	GAB31 A12 DW	GAB31 A85 DW	GAB41 A85 DW	GAB41 A66 DW
Model	Banko M3 ANGLE	Banko M3 ANGLE	Banko M4 ANGLE	Banko M4 ANGLE
Max. free speed (rpm)	12000	8500	8500	6600
Spindle thread	M14	M14	M14	M14
Rec. max. dia. grinding wheel	125	180	180	230
Maximum Power (kW)	1.8	1.8	2.8	2.8
Weight (kg)	2.6	2.6	3.4	3.4
Length (mm)	338	338	337	337
Rec. hose dia. (mm)	19	19	19	19
Air inlet thread	1/2"	1/2"	1/2"	1/2"
Optimal pressure (bar)	6.3	6.3	6.3	6.3
Air consumption max/free (l/sec)	32/16	32/16	50/18	50/18
Exhaust	Lateral	Lateral	Lateral	Lateral
Noise (dB)	91	91	92	92
Vibration	<4.9 m/s ²	<4.7 m/s ²	<4.8 m/s ²	<4.8 m/s ²

VANE MACHINE OIL FREE

Oiled air can be used at any time, increases the service life of the machine

















Patented technology



Grinder extensions

Middle extension

Last extension

		(140 mm)	(housing 140 mm)
 <p>Order number GSB41 S12 E1-01</p> <p>Grinder technical information at page 14, 16 and 17.</p>	+		
 <p>Order number GSB31 S18 E2-01</p> <p>Grinder technical information at page 14, 16 and 17.</p>	+		 <p>E1-03-01 (Collet CE 6 mm) E1-03-01 8 (Collet CE 8 mm) E1-03-03 (Collet CES 6 mm) E1-03-03 8 (Collet CES 8 mm)</p>  <p>E1-03-02 (CW M 12x1)</p>
 <p>Order number GSB41PT S10 E4-05</p> <p>Grinder technical information at page 14, 16 and 17.</p>	+	 <p>E1-02</p>	 <p>E1-03-04 (Angle collet CES 6 mm) E1-03-04 8 (AngleCollet CES 8 mm)</p>
 <p>Order number GDB11 E25 E4-01</p> <p>Grinder technical information at page 13 and 15.</p>	+		 <p>CE</p>  <p>CES</p>
 <p>Order number GDB12 E25 E4-02</p> <p>Grinder technical information at page 13 and 15.</p>	+		 <p>Adapter CW - CE</p>  <p>Adapter CW</p>
 <p>Order number GDB21 E18 E4-03</p> <p>Grinder technical information at page 13 and 15.</p>	+		 <p>Adapter CW-SW</p>

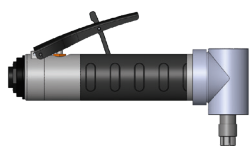

Recommendation for GDB01 Die and Die Extended models (article C1-16-01): 1 m supply air hose with coupling and silencer

DIE ANGLE M0

DIE angle grinder

Order number	GDB01 A25 CES	GDB01 A18 CES	GDB01 A25 CE	GDB01 A18 CE
Model	Banko M0 Die Angle	Banko M0 Die Angle	Banko M0 Die Angle	Banko M0 Die Angle
Max. free speed (rpm)	25000	18000	25000	18000
Collet (mm)	6	6	6	6
Rec. / max. dia. carbide burr (mm)	12/16	12/16	12/16	12/16
Rec. / max. dia. mounted point (mm)	20/25	20/25	20/25	20/25
Maximum Power (kW)	0.75	0.75	0.75	0.75
Weight (kg)	0.99	0.99	0.99	0.99
Length (mm)	206.9	206.9	206.9	206.9
Rec. hose dia. (mm)	10	10	10	10
Air inlet thread	3/8"	3/8"	3/8"	3/8"
Optimal pressure (bar)	6.3	6.3	6.3	6.3
Air consumption max/free (l/sec)	14/8	14/8	14/8	14/8
Exhaust	Rear	Rear	Rear	Rear
Noise (dB)	84	84	84	84
Vibration	<2.5 m/s ²	<2.5 m/s ²	<2.5 m/s ²	<2.5 m/s ²



DIE ANGLE M-2

DIE angle grinder

with collet (CE)

with thread (CW)

with collet (CE)

with thread (CW)

Order number	GAB21 D12 CE	GAB21 D12 CW	GTB21 D12 CE	GTB21 D12 CW
Model	Banko M2 Die Angle	Banko M2 Die Angle	Banko T21 Angle	Banko T21 Angle
Max. free speed (rpm)	12000	12000	12000	12000
Rec. / max. dia. carbide burr (mm) / cone wheel (50 m/s)	12/16	12/16	32/40	63/80
Maximum Power (kW)	2.2	2.2	3.5	3.5
Weight (kg)	1.9	1.9	1.9	1.9
Length (mm)	265	265	243	243
Rec. hose dia. (mm)	13	13	13	13
Air inlet thread	1/2"	1/2"	1/2"	1/2"
Optimal pressure (bar)	6.3	6.3	6.3	6.3
Air consumption max/free (l/sec)	32/16	32/16	45/14	45/14
Exhaust	Rear	Rear	Lateral	Lateral
Noise (dB)	90	90	78	78
Vibration	<3.2 m/s ²	<3.2 m/s ²	<3 m/s ²	<3 m/s ²

Collet: standard delivery 6 mm. Optional dimension of collet available (please specify when ordering)

VANE MACHINE OIL FREE

Oiled air can be used at any time, increases the service life of the machine

BANKO

Patented technology



DIE M-0

DIE grinder with collet (CE)



DIE EXTENDED M-0

DIE grinder with collet (CE)

Order number	GDB01 D25 CE	GDB01 D18 CE	GDB01 E25 CE	GDB01 E18 CE
Model	Banko M0 Die	Banko M0 Die	Banko M0 Die Extended	Banko M0 Die Extended
Max. free speed (rpm)	25000	18000	25000	18000
Collet (mm)	6	6	6	6
Rec. / max. dia. carbide burr (mm)	12/16	12/16	12/16	12/16
Rec. / max. dia. mounted point (mm)	20/25	20/25	20/25	20/25
Maximum Power (kW)	0.75	0.75	0.75	0.75
Weight (kg)	0.8	0.8	1.0	1.0
Length (mm)	215	215	322	322
Rec. hose dia. (mm)	10	10	10	10
Air inlet thread	3/8"	3/8"	3/8"	3/8"
Optimal pressure (bar)	6.3	6.3	6.3	6.3
Air consumption max/free (l/sec)	14/8	14/8	14/8	14/8
Exhaust	Rear	Rear	Rear	Rear
Noise (dB)	84	85	84	85
Vibration	<2.5 m/s ²	<2.5 m/s ²	<2.5 m/s ²	<2.5 m/s ²

Collet: standard delivery 6 mm. Optional dimension of collet available (please specify when ordering)



DIE EXTENDED M-0

With extra thin front part (20 mm outside diameter) and CES collet

Order number	GDB01 EE20 25 CES	GDB01 EE20 18 CES
Model	Banko M0 Die Extended	Banko M0 Die Extended
Max. free speed (rpm)	25000	18000
Collet (mm)	6	6
Rec. / max. dia. carbide burr (mm)	12/16	12/16
Rec. / max. dia. mounted point (mm)	20/25	20/25
Maximum Power (kW)	0.75	0.75
Weight (kg)	0.9	0.9
Length (mm)	420	420
Rec. hose dia. (mm)	10	10
Air inlet thread	3/8"	3/8"
Optimal pressure (bar)	6.3	6.3
Air consumption max/free (l/sec)	14/8	14/8
Exhaust	Rear	Rear
Noise (dB)	84	85
Vibration	<2.5 m/s ²	<2.5 m/s ²

Collet: standard delivery 6 mm. Optional dimension of collet available (please specify when ordering)



DIE M-1

DIE grinder with collet (CE)

DIE M-1 VD

DIE grinder with collet (CE)

Order number	GDB11 D25 CE	GDB11 D18 CE	GDB11 D25 CE VD	GDB11 D18 CE VD
Model	Banko M1 Die	Banko M1 Die	Banko M1 Die VD	Banko M1 Die VD
Max. free speed (rpm)	25000	18000	25000	18000
Collet (mm)	6/8	6/8	6/8	6/8
Rec. / max. dia. carbide burr (mm)	12/16	16/16	12/16	16/16
Rec. / max. dia. mounted point (mm)	25/32	32/40	25/32	32/40
Maximum Power (kW)	1.4	1.3	1.4	1.3
Weight (kg)	1.1	1.1	1.1	1.1
Lenght (mm)	234	234	234	234
Rec. hose dia. (mm)	13	13	13	13
Air inlet thread	1/2"	1/2"	1/2"	1/2"
Optimal pressure (bar)	6.3	6.3	6.3	6.3
Air consumption max/free (l/sec)	20/12	18/12	20/12	18/12
Exhaust	Rear	Rear	Rear	Rear
Noise (dB)	90	87	90	87
Vibration	<2.5 m/s ²	<2.5 m/s ²	<2.5 m/s ²	<2.5 m/s ²

Collet: standard delivery 6 mm. Optional dimension of collet available (please specify when ordering)

VD - VIBRATION DUMPED MACHINE

for smooth grinding without chatters (only carbide burrs)



Recommendation for GDB11 Die and Die Extended models (article B1-16-03):
1 m supply air hose with coupling and silencer

VANE MACHINE OIL FREE

Oiled air can be used at any time, increases the service life of the machine

BANKO

Patented technology



DIE EXTENDED M-1

DIE grinder with collet (CE)

Order number	GDB11 E25 CE	GDB11 E18 CE
Model	Banko M1 Die Extended	Banko M1 Die Extended
Max. free speed (rpm)	25000	18000
Collet (mm)	6/8	6/8
Rec. / max. dia. carbide burr (mm)	12/16	16/16
Rec. / max. dia. mounted point (mm)	20/32	32/40
Maximum Power (kW)	1.4	1.3
Weight (kg)	1.5	1.5
Length (mm)	372	372
Rec. hose dia. (mm)	13	13
Air inlet thread	1/2"	1/2"
Optimal pressure (bar)	6.3	6.3
Air consumption max/free (l/sec)	20/12	18/12
Exhaust	Rear	Rear
Noise (dB)	90	87
Vibration	<2.5 m/s ²	<2.5 m/s ²

Collet: standard delivery 6 mm. Optional dimension of collet available (please specify when ordering)



DIE EXTENDED M-12

Die grinder with collet (CE)

DIE EXTENDED M-21

Die grinder with collet (CE)

Order number	33.543 mm	GDB12 E18 CE	GDB21 E18 CE	GDB21 E15 CE
Model	Banko M12 Die Extended	Banko M12 Die Extended	Banko M12 Die Extended	Banko M12 Die Extended
Max. free speed (rpm)	25000	18000	18000	15000
Collet (mm)	6/8	6/8	6/8	6/8
Rec. / max. dia. carbide burr (mm)	12/16	12/16	12/16	12/16
Rec. / max. dia. mounted point (mm)	20/25	20/25	32/40	32/40
Maximum Power (kW)	1.5	1.4	2.2	2.1
Weight (kg)	1.4	1.4	1.9	1.9
Length (mm)	390	390	398	398
Rec. hose dia. (mm)	13	13	13	13
Air inlet thread	1/2"	1/2"	1/2"	1/2"
Optimal pressure (bar)	6.3	6.3	6.3	6.3
Air consumption max/free (l/sec)	20/12	18/12	38/17	36/17
Exhaust	Lateral	Lateral	Lateral	Lateral
Noise (dB)	87	86	88	87
Vibration	<2.5 m/s ²	<2.5 m/s ²	<3.2 m/s ²	<3.2 m/s ²

Collet: standard delivery 6 mm. Optional dimension of collet available (please specify when ordering)



STRAIGHT M-3

Straight grinder with collet (CE)

Order number	GSB31 S18 CE
Model	Banko M3 Straight
Max. free speed (rpm)	18000
Collet diameter (mm)	6/8
Maximum Power (kW)	2.0
Weight (kg)	2.2
Length (mm)	440
Rec. hose dia. (mm)	13
Air inlet thread	1/2"
Optimal pressure (bar)	6.3
Air consumption max/free (l/sec)	32/16
Exhaust	Lateral
Noise (dB)	91
Vibration	<3.5 m/s ²

Collet: standard delivery 6 mm. Optional dimension of collet available (please specify when ordering)



STRAIGHT M-4

Straight grinder with collet (CE)

Order number	GSB41 S12 CE	GSB41 S10 CE
Model	Banko M4 Straight	Banko M4 Straight
Max. free speed (rpm)	12000	10000
Collet diameter (mm)	6/8	6/8
Maximum Power (kW)	3.1	3.0
Weight (kg)	2.9	2.9
Length (mm)	435	435
Rec. hose dia. (mm)	19	19
Air inlet thread	1/2"	1/2"
Optimal pressure (bar)	6.3	6.3
Air consumption max/free (l/sec)	50/18	48/18
Exhaust	Lateral	Lateral
Noise (dB)	89	87
Vibration	<4.5 m/s ²	<4.3 m/s ²

Collet: standard delivery 6 mm. Optional dimension of collet available (please specify when ordering)

VANE MACHINE OIL FREE

Oiled air can be used at any time, increases the service life of the machine

BANKO

Patented technology



DIE EXTENDED M-1

Die grinder for grinding tools with thread (CW)

Order number	GDB11 E25 CW	GDB11 E18 CW
Model	Banko M1 Die Extended	Banko M1 Die Extended
Max. free speed (rpm)	25000	18000
Spindle thread	M12x1*	M12x1*
Rec. / max. dia. cone wheel (50 m/s)	32/40	40/50
Maximum Power (kW)	1.4	1.3
Weight (kg)	1.5	1.5
Length (mm)	346	346
Rec. hose dia. (mm)	13	13
Air inlet thread	1/2"	1/2"
Optimal pressure (bar)	6.3	6.3
Air consumption max/free (l/sec)	20/12	18/12
Exhaust	Rear	Rear
Noise (dB)	90	87
Vibration	<2.5 m/s ²	<2.5 m/s ²

* INFO: 1 machine = 1 wheel adapter free of charge (please specify when ordering)



DIE EXTENDED M-12

DIE grinder for grinding tools with thread (CW)

DIE EXTENDED M-21

DIE grinder for grinding tools with thread (CW)

Order number	GDB12 E25 CW	GDB12 E18 CW	GDB21 E18 CW	GDB21 E15 CW
Model	Banko M12 Die Extended	Banko M12 Die Extended	Banko M21 Die Extended	Banko M21 Die Extended
Max. free speed (rpm)	25000	18000	18000	15000
Spindle thread	M12x1*	M12x1*	M12x1*	M12x1*
Rec. / max. dia. carbide burr (mm)	12/16	12/16	12/16	12/16
Rec. / max. dia. mounted point (mm)	20/25	20/25	32/40	32/40
Maximum Power (kW)	1.5	1.4	2.2	2.1
Weight (kg)	1.4	1.4	1.9	1.9
Length (mm)	382	382	390	390
Rec. hose dia. (mm)	13	13	13	13
Air inlet thread	1/2"	1/2"	1/2"	1/2"
Optimal pressure (bar)	6.3	6.3	6.3	6.3
Air consumption max/free (l/sec)	20/12	18/12	38/17	36/17
Exhaust	Lateral	Lateral	Lateral	Lateral
Noise (dB)	87	86	88	87
Vibration	<2.5 m/s ²	<2.5 m/s ²	<3.2 m/s ²	<3.2 m/s ²

* INFO: 1 machine = 1 wheel adapter free of charge (please specify when ordering)



STRAIGHT M-3

Straight grinder for grinding tools with thread (CW)

STRAIGHT M-4

Straight grinder for grinding tools with thread (CW)

Order number	GSB31 S18 CW	GSB31 S15 CW	GSB41 S12 CW	GSB41 S10 CW
Model	Banko M3 Straight	Banko M3 Straight	Banko M4 Straight	Banko M4 Straight
Max. free speed (rpm)	18000	15000	12000	10000
Spindle thread	M12x1*	M12x1*	M12x1*	M12x1*
Rec. / max. dia. cone wheel (50 m/s)	40/50	50/63	63/80	80/100
Maximum Power (kW)	2.0	1.9	3.1	3.0
Weight (kg)	2.2	2.2	2.9	2.9
Length (mm)	440	440	435	435
Rec. hose dia. (mm)	13	13	19	19
Air inlet thread	1/2"	1/2"	1/2"	1/2"
Optimal pressure (bar)	6.3	6.3	6.3	6.3
Air consumption max/free (l/sec)	32/16	30/16	47/18	47/16
Exhaust	Lateral	Lateral	Lateral	Lateral
Noise (dB)	91	89	89	87
Vibration	<3.5 m/s ²	<3.3 m/s ²	<4.5 m/s ²	<4.3 m/s ²

* INFO: 1 machine = 1 wheel adapter free of charge (please specify when ordering)

Available on request: Adapter CW (M12x1) – CE (Collet 6 mm). Optional dimension of collet available (please specify when ordering)

STRAIGHT M-4 POWER

Straight grinder for grinding tools with thread (CW)

Order number	GSB41P S10 CW	GSB41P S85 CW	GSB41P S66 CW	GSB41PT S10 CW	GSB41PT S85 CW	GSB41PT S66 CW
Model	Banko M4P Straight	Banko M4P Straight	Banko M4P Straight	Banko M4PT Straight	Banko M4PT Straight	Banko M4PT Straight
Max. free speed (rpm)	10000	8500	6600	10000	8500	6600
Spindle thread	M12x1*	M12x1*	M12x1*	M12x1*	M12x1*	M12x1*
Rec/max dia. cone wheel (50 m/s)	80/100	80/100	80/100	80/100	80/100	80/100
Maximum Power (kW)	3.3	3.3	3.2	3.3	3.3	3.2
Weight (kg)	4.2	4.2	4.2	4.2	4.2	4.2
Length (mm)	470	470	470	470	470	470
Rec. hose dia. (mm)	16	16	16	16	16	16
Air inlet thread	1/2"	1/2"	1/2"	1/2"	1/2"	1/2"
Optimal pressure (bar)	6.3	6.3	6.3	6.3	6.3	6.3
Air consumption max/free (l/sec)	52/18	51/18	51/18	52/18	51/18	51/18
Exhaust	Lateral	Lateral	Lateral	Lateral	Lateral	Lateral
Noise (dB)	93	91	89	93	91	89
Vibration	<4.6 m/s ²	<4.3 m/s ²	<4.1 m/s ²	<4.6 m/s ²	<4.3 m/s ²	<4.1 m/s ²

* INFO: 1 machine = 1 wheel adapter free of charge (please specify when ordering)

Available on request: Adapter CW (M12x1) – CE (Collet 6 mm). Optional dimension of collet available (please specify when ordering)

VANE MACHINE OIL FREE

Oiled air can be used at any time, increases the service life of the machine

BANKO

Patented technology



STRAIGHT M-3

Straight grinder for straight wheel (SW)

STRAIGHT M-4

Straight grinder for straight wheel (SW)

Order number	GSB31 S18 SW	GSB31 S15 SW	GSB41 S12 SW	GSB41 S10 SW
Model	Banko M3 Straight	Banko M3 Straight	Banko M4 Straight	Banko M4 Straight
Max. free speed (rpm)	18000	15000	12000	10000
Spindle thread	UNC 5/8x55*	UNC 5/8x55*	UNC 5/8x55*	UNC 5/8x55*
Rec. / max. dia. straight wheel (80 m/s)	80/80	80/80	125/125	125/150
Maximum Power (kW)	2.0	1.9	3.1	3.0
Weight (kg)	2.2	2.2	2.9	2.9
Lenght (mm)	472	472	467	467
Rec. hose dia. (mm)	13	13	19	19
Air inlet thread	1/2"	1/2"	1/2"	1/2"
Optimal pressure (bar)	6.3	6.3	6.3	6.3
Air consumption max/free (l/sec)	32/16	30/16	50/18	48/18
Exhaust	Lateral	Lateral	Lateral	Lateral
Noise (dB)	91	89	89	87
Vibration	<3.5 m/s ²	<3.3 m/s ²	<4.5 m/s ²	<4.3 m/s ²

* INFO: 1 machine = 1 wheel adapter free of charge (please specify when ordering)

STRAIGHT M-4 POWER

Straight grinder for straight wheel (SW)

Order number	GSB41P S10 SW	GSB41P S85 SW	GSB41P S66 SW	GSB41PT S10 SW	GSB41PT S85 SW	GSB41PT S66 SW
Model	Banko M4P Straight	Banko M4P Straight	Banko M4P Straight	Banko M4PT Straight	Banko M4PT Straight	Banko M4PT Straight
Max. free speed (rpm)	10000	8500	6600	10000	8500	6600
Spindle thread	UNC 5/8x55*	UNC 5/8x55*	UNC 5/8x55*	UNC 5/8x55*	UNC 5/8x55*	UNC 5/8x55*
Rec. / max. dia. straight wheel (80 m/s)	125/150	180/180	230/230	125/150	125/150	125/150
Maximum Power (kW)	3.3	3.3	3.2	3.3	3.3	3.2
Weight (kg)	4.2	4.2	4.2	4.2	4.2	4.2
Lenght (mm)	470	470	470	470	470	470
Rec. hose dia. (mm)	16	16	16	16	16	16
Air inlet thread	1/2"	1/2"	1/2"	1/2"	1/2"	1/2"
Optimal pressure (bar)	6.3	6.3	6.3	6.3	6.3	6.3
Air consumption max/free (l/sec)	52/18	51/18	51/18	52/18	51/18	51/18
Exhaust	Lateral	Lateral	Lateral	Lateral	Lateral	Lateral
Noise (dB)	93	91	89	93	91	89
Vibration	<4.6 m/s ²	<4.3 m/s ²	<4.1 m/s ²	<4.6 m/s ²	<4.3 m/s ²	<4.1 m/s ²

* INFO: 1 machine = 1 wheel adapter free of charge (please specify when ordering)

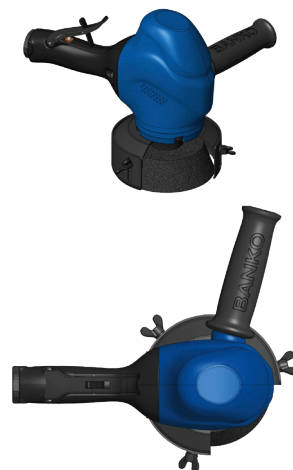
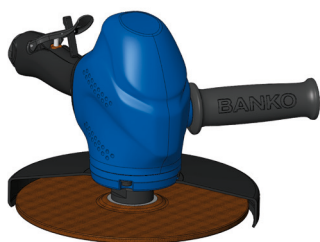

VERTICAL M-5 POWER

Vertical grinder (DW)

Order number	GVB51P V85 DW	GVB51P V66 DW
Model	Banko M5P Vertical	Banko M5P Vertical
Max. free speed (rpm)	8500	6600
Spindle thread	5/8"-11	5/8"-11
Rec. max. dia. grinding wheel	180	230
Maximum Power (kW)	3.2	3.1
Weight (kg)	4.9	4.9
Length (mm)	210	210
Rec. hose dia. (mm)	19	19
Air inlet thread	1/2"	1/2"
Optimal pressure (bar)	6.3	6.3
Air consumption max/free (l/sec)	54/17	52/17
Exhaust	Lateral	Lateral
Noise (dB)	89	88
Vibration	<5.2 m/s ²	<4.9 m/s ²

Vertical grinder for cup wheels (CW)

Order number	GVB51P V66 CW
Model	Banko M5P Vertical
Max. free speed (rpm)	6600
Spindle thread	5/8"-11
Rec. max. dia. grinding wheel	140/115x65
Maximum Power (kW)	3.1
Weight (kg)	4.9
Length (mm)	210
Rec. hose dia. (mm)	19
Air inlet thread	1/2"
Optimal pressure (bar)	6.3
Air consumption max/free (l/sec)	52/17
Exhaust	Lateral
Noise (dB)	88
Vibration	<4.9 m/s ²

THE BEASTS

FOR ROBOTS

BANKO
INDUSTRIAL POWER TOOLS

The most powerful grinders with compliance units available in the market

Unmatched power
provide extreme
material removal rate
which allows new levels
of productivity

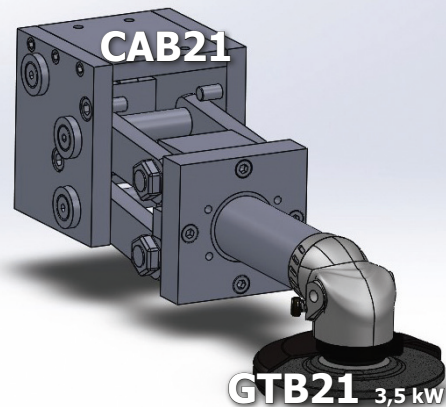
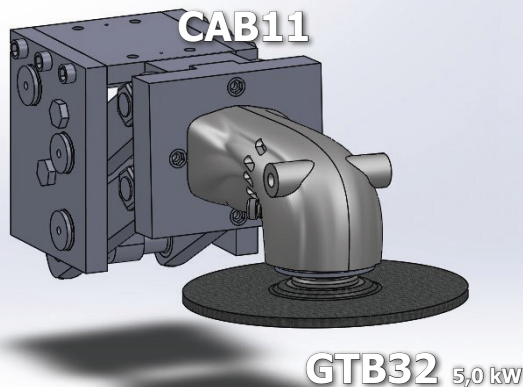
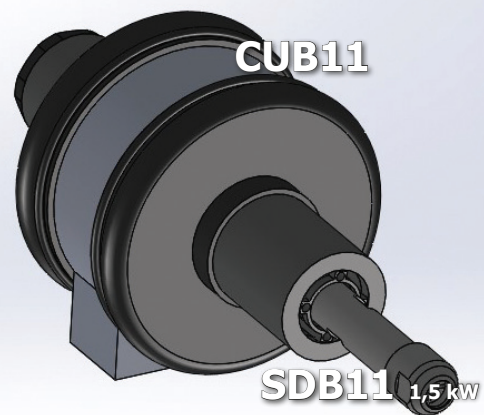

Benefits

- ▶ The most efficient grinding for an extreme material removal rate
- ▶ Much less insensitivity to variation of pressure, impossible to stall with the right hose and pressure
- ▶ Grinding with much less vibration due to grinding of the wheel at the constant right speed
- ▶ Oil-less grinding which enables clean surface and more environmentally friendly operation

Features

- ▶ The most efficient turbine motor
- ▶ Precise stainless steel governor working under any pressure and condition

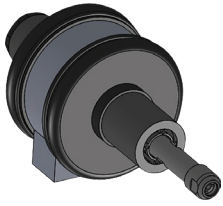

Spindle with compliance unit

Order number	SDB11 D35 CE	SDB11 D30 CE	SDB21 D35 CE	SDB32 D35 CE
Model	Banko T11 Spindle	Banko T11 Spindle	Turbine T21	Turbine T32
Max. free speed (rpm)	35000	30000	35000	35000
Collet (mm)	6/8	6/8	6/8	6/8
Rec. / max. dia. carbide burr (mm)	12 / 16	12 / 16	12 / 16	12 / 16
Maximum Power (kW)	1.5	1.5	3.5	5.0
Rec. hose dia. (mm)	13	13	13	16
Air inlet thread	1/2"	1/2"	1/2"	1/2"
Optimal pressure (bar)	6.3	6.3	6.3	6.3
Air consumption max/free (l/sec)	32/10	32/10	45/14	62/18
Exhaust	Front	Front	Front	Front
Noise (dB)	77	76	78	87
Compliance unit	CUB11	CUB11	CUB21	CUB32

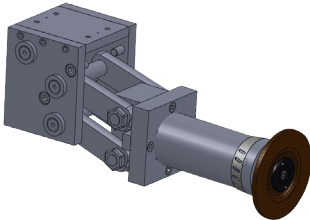

T51 Spindle with compliance unit

Order number	SDB51 D18 CE	SDB11 D30 CE
Model	Banko T51 Spindle	Banko T51 Spindle
Max. free speed (rpm)	18000	15000
Collet (mm)	6/8	6/8
Rec. / max. dia. carbide burr (mm)	12 / 16	12 / 16
Maximum Power (kW)	5.0	5.0
Rec. hose dia. (mm)	16	16
Air inlet thread	1/2"	1/2"
Optimal pressure (bar)	6.3	6.3
Air consumption max/free (l/sec)	65/19	65/19
Exhaust	Front	Front
Noise (dB)	88	88
Compliance unit	CAB51	CAB51

TURBINE GRINDER
ABSOLUTELY OIL-FREE

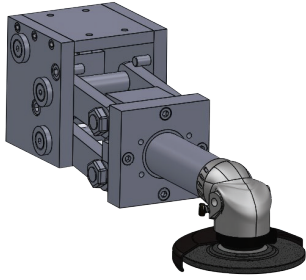

Angle grinder with compliance unit

Order number	GTB21 A12 RW	GTB21 A85 RW	GTB21 A12 RW58	GTB21 A85 RW58
Model	Banko T21 Angle	Banko T21 Angle	Banko T21 Angle	Banko T21 Angle
Max. free speed (rpm)	12000	8500	12000	8500
Spindle thread	M14	M14	5/8"-11	5/8"-11
Rec. max. dia. grinding wheel	125	180	125	180
Maximum Power (kW)	3.5	3.5	3.5	3.5
Rec. hose dia. (mm)	13	13	13	13
Air inlet thread	1/2"	1/2"	1/2"	1/2"
Optimal pressure (bar)	6.3	6.3	6.3	6.3
Air consumption max/free (l/sec)	45/14	45/14	45/14	45/14
Exhaust	Lateral	Lateral	Lateral	Lateral
Noise (dB)	78	79	78	79
Compliance unit	CAB21	CAB21	CAB21	CAB21

We recommend the gear grease (article 490-16-103) for relubrication.

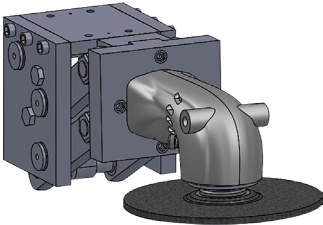

Angle grinder with compliance unit

Order number	GTB32 A85 RW	GTB32 A66 RW	GTB32 A85 RW58	GTB32 A66 RW58
Model	Banko T32 Angle	Banko T32 Angle	Banko T32 Angle	Banko T32 Angle
Max. free speed (rpm)	8500	6600	8500	6600
Spindle thread	M14	M14	5/8"-11	5/8"-11
Rec. max. dia. grinding wheel	180	230	180	230
Maximum Power (kW)	5.0	5.0	5.0	5.0
Rec. hose dia. (mm)	16	16	16	16
Air inlet thread	1/2"	1/2"	1/2"	1/2"
Optimal pressure (bar)	6.3	6.3	6.3	6.3
Air consumption max/free (l/sec)	52/18	52/19	52/18	52/19
Exhaust	Lateral	Lateral	Lateral	Lateral
Noise (dB)	87	87	87	87
Compliance unit	CAB11	CAB11	CAB11	CAB11

We recommend the gear grease (article 490-16-103) for relubrication.

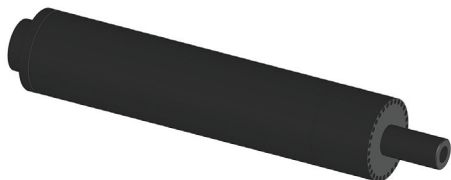

VANE MOTOR

Order number	MDB01 D25 CE	MDB11 D25 CE	MDB21 D18 CE	MDB41P D10 CE
Model	Banko M0 motor	Banko M1 motor	Banko M2 motor	Banko M4P motor
Max. free speed (rpm)	25000	25000	18000	10000
Maximum Power (kW)	0.75	1.4	2.2	3.3
Weight (kg)	0.9	1.0	1.7	2.1
Length (mm)	190	200	200	180
Rec. hose dia. (mm)	10	13	13	16
Air inlet thread	3/8"	1/2"	1/2"	1/2"
Optimal pressure (bar)	6.3	6.3	6.3	6.3
Air consumption max/free (l/sec)	14/8	20/12	32/16	52/18
Exhaust	Front	Front	Front	Front
Noise (dB)	84	90	90	93
Vibration	<2.5 m/s ²	<2.5 m/s ²	<3.2 m/s ²	<4.6 m/s ²
Also available with Max free speed (rpm)	18000	18000	15000	8500

Collet: standard delivery 6 mm. Optional dimension of collet available (please specify when ordering)

Version with CW (internal thread M12 x 1 mm for grinding wheels with thread) also available.

Available on request: Other speed, other length, 90° angle head.

TURBINE GRINDER
ABSOLUTELY OIL-FREE

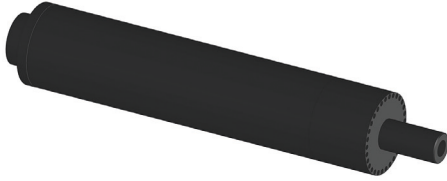

TURBINE MOTOR

Order number	SDB11 D35 CE	SDB21 D35 CE	SDB32 D35 CE	SDB51 D18 CE
Model	Turbine T11	Turbine T21	Turbine T32	Turbine T51
Max. free speed (rpm)	35000	35000	35000	18000
Maximum Power (kW) KW	1.5	3.5	5.0	5.0
Weight (kg)	1.0	1.8	2.2	4.0
Length (mm)	180	200	200	300
Rec. hose dia. (mm)	13	13	16	16
Air inlet thread	1/2"	1/2"	1/2"	1/2"
Optimal pressure (bar)	6.3	6.3	6.3	6.3
Air consumption max/free (l/sec)	32/10	45/14	62/18	65/19
Exhaust	Front	Front	Front	Front
Noise (dB)	76	78	87	88
Vibration	<3 m/s ²	<3 m/s ²	<3.5 m/s ²	<3.8 m/s ²
Also available with Max free speed (rpm)	25000	30000	30000	15000

Collet: standard delivery 6 mm. Optional dimension of collet available (please specify when ordering)

Version with CW (internal thread M12 x 1 mm for grinding wheels with thread) also available.

Available on request: Other speed, other length, 90° angle head.

BANKO

PATENTED TECHNOLOGY



MADE IN EU / CROATIA

BANKO INDUSTRIAL POWER TOOLS d.o.o. Contact:

Address:

Dubrovačka 19

21000 Split

Croatia

Production:

Hrvatskih velikana 26a

21251 Žrnovnica

Croatia

Tel.: + 385 21 540 010

Fax: + 385 21 540 022

info@banko.hr

www.banko.hr